



**BROWNS VALLEY CITY COUNCIL MEETING
BROWNS VALLEY PUBLIC LIBRARY MEETING ROOM
Monday March 13, 2023 - 5:30 P.M.**

AGENDA

Call to order

Pledge of Allegiance

Roll Call: Mike Heck Tony Miller Neil Madison Jan Biewer Devan Dobbs

Others in attendance: Jodi Hook-Hansen, Tony Serocki, Bernice Piechowski, Terry Biewer, Matt Franzese

Absent:

Public Hearing: None

Approval of Agenda:

Consent Agenda

➤ February 27, 2023 Regular Meeting Minutes

➤ For a grand total of \$

Wages: March 1st = \$10,827.83

Claims: March 13th = \$25,091.43

➤ Treasurers report

➤ Delinquency report

Department Reports: Sheriff's Dept-Ambulance-Fire Department-Public Works-Library-Admin/Code Officer

Communications:

Unfinished Business:

New Business:

➤ Richard Johnson-Historical Society

➤ Wireless Router, Security Cameras – Park Region

➤ Christmas decoration lights for street poles.

➤ Discussion of Water Accountability, Inactive Accounts and Rate Study.

Other Business:

Public Forum:

Dates: March 27th - Completed Audit

April 10th 2:30 - Board of Appeals and Equalization in Library Meeting Room

Items for council to consider for future: Appointments to review Personnel Handbook and Ordinance Book & EDA Committee

Next scheduled meeting Monday March 27 - 5:30 PM

Adjournment: Time _____

NOTE: The agenda is produced in advance of the council meeting. The actual meeting may consist of additional items, as may come before the council after the agenda is posted, or during the meeting itself.



Browns Valley Regular City Council Meeting Approved Minutes February 27, 2023

The regular council meeting of the City of Browns Valley, MN was held in the meeting room of the Public Library. Council members present were Mayor Mike Heck, Neil Madison, Tony Miller, Devan Dobbs, Jan Biewer. Also, in attendance were City Maintenance Tony Serocki, City Administrator Jodi Hook-Hansen, Library Director Bernice Piechowski, Code Enforcement Officer Terry Biewer and City Attorney Matt Franzese.

Absent: None

Others present: Edith Foren, Richard Johnson, Todd Johnson, and Andy Miller, (Traverse County Sheriff's Office)

The meeting was called to order at 5:30 p.m. by Mayor Heck.
The Pledge of Allegiance was recited by those in attendance.

Agenda

Upon a motion by Dobbs with a second by Madison, the Council unanimously approved the agenda with the additions of 20-0222000 Garage near 232 Church; 20-0161000 at 414 W Broadway (BJ's), Bob Lee-Mowing and Approval of Liquor License Resolution 23-08.

Public Hearing: None at this time.

Consent Agenda

- Upon a motion by Biewer with a second by Miller, the Council unanimously approved the February 13, 2023, Regular Meeting Minutes.
- Upon a motion by Biewer with a second by Madison, the Council unanimously approved the claims for a grand total of \$34,136.68 to include Wages February 16th = \$6,990.39 and the Claims: February 27th = \$27,146.29

Department Reports:

- Deputy Miller was present from the Sheriff's office and presented the Council with a completed 2022 yearly report for the Traverse County Sheriff's Office. The report indicated the calls dispatched received from Browns Valley were 536 down compared to 772 in 2021.
- City Administrator Hook-Hansen gave a verbal report on administrative items completed in the office.
- Library Director Piechowski gave a verbal report about activities at the library.
- Code Enforcement Officer Biewer gave a verbal report on actions done to enforce City ordinances and items completed in the office.
- City Maintenance Serocki gave a verbal report on public works items completed.

- City Attorney Franzese gave a verbal report to the council on items he has completed to include administrative search warrants, ordinance review, and informed the council about options of THC/CBD licensing or an ordinance moratorium on THC/CBD.
- Upon a motion by Dobbs with a second by Miller, the Council unanimously approved to have City Attorney Franzese to move forward with an ordinance moratorium on THC/CBD.

Communications: Jan Biewer informed the Council that she had spoke with Dorothy Christensen in regards to the Food Shelf utilizing the Community Center. Dorothy informed Biewer that last year they served 24 families and 77 people. Families are able to visit once a month unless emergency.

Unfinished Business: None at this time.

New Business:

- Hook-Hansen received complaint from Council member Dobbs and she informed the council about the Facebook postings. Hook-Hansen also informed the council about inquiry to Brian D. Koehn, CPA, PLLC.
- Upon a motion by Miller with a second by Biewer, the Council unanimously approved the Resolution 23-07 a Resolution Affirming Corporate Authorized Signers for the City of Browns Valley for the Year of 2023.
- Mayor Heck appointed Madison and Biewer to meet with Attorney Franzese for recommendations/review of Amendment to Ordinances Sec 92.21 and 92.23 and Establishment of Ordinance Sec 92.25.
- The Council members continued the discussion of Water Accountability, Inactive Accounts and Rate Study. Council member Dobbs asked staff to consider bracket rates for usage consumptions, which will increase usage rates for more gallons used. The increased usage rates will mostly affect the Nursing Home, School, Apartments and some residents.

Other Business:

- Upon a motion by Heck with a second by Biewer, the Council unanimously approved the contract to sell to Larry Hall parcel ID 20-0222000 Garage near 232 Church St in the amount of \$750.00 plus transfer fee.
- Upon a motion by Madison with a second by Biewer, the Council denied sealed bids with a minimum amount located at 414 W Broadway parcel ID 20-0161000 (AKA BJ's). Aye's Dobbs and Madison. Nay's Miller, Heck and Biewer.
- Upon a motion by Miller with a second by Biewer, the Council on 4 to 1 approved the contract to sell to John Meyen and Curt Ritter parcel ID 20-0161000 and vacant lot to the east. (AKA BJ's) located at 414 W Broadway in the amount of \$6,500.00 plus transfer fee. Dobbs dissented.
- Bob Lee introduced himself and inquired if his company could contract for City mowing. Mr. Lee gave council certificate of insurance and the council informed Mr. Lee that they will call if needed.

**Browns Valley Regular City Council Meeting Approved Minutes
February 27, 2023**

- Upon a motion by Dobbs with a second by Miller, the Council unanimously approved the of Liquor License Resolution 23-08 a Resolution Approving Beer and Liquor Licenses for Browns Valley Liquor Store and American Legion.

Public Forum: None at this time.

Next scheduled meeting Monday March 13 - 5:30 PM

Dates February 20th Office Closed – February 23rd EDA Committee
April 10th 2:30 - Board of Appeals and Equalization in Library Meeting Room

Items for council to consider for future: Committees to review Personnel Handbook and Ordinance Book & EDA Committee.

Next scheduled meeting: Monday February 27th at 5:30 p.m.

The meeting adjourned at 7:42 p.m.

Minutes submitted by:

Approved by:

Jodi Hook-Hansen, City Administrator

Mike Heck, Mayor / Acting Mayor

BROWNS VALLEY, MN

03/08/23 3:16 PM

Page 1

Payments

Current Period: March 2023

Payment Batch Claims031323		\$25,901.43	
Refer	<u>653 BRIAN D KOEHN, CPA, PLLC</u>	<u>Ck# 019612 3/13/2023</u>	
Cash Payment	E 101-41000-301 Audit & Acct Services	audit of financial statements year end 2022	\$5,000.00
Invoice	1022	3/1/2023	
Transaction Date	3/2/2023	PRAIRIE SUN BANK 10100	Total \$5,000.00
Refer	<u>654 SCHMIDT LAW + CONSULTING</u>	<u>Ck# 019628 3/13/2023</u>	
Cash Payment	E 101-41610-304 Legal Fees	GENERAL OPERATIONS	\$250.00
Invoice	79	3/1/2023	
Transaction Date	3/2/2023	PRAIRIE SUN BANK 10100	Total \$250.00
Refer	<u>655 MED COMPASS</u>	<u>Ck# 019622 3/13/2023</u>	
Cash Payment	E 101-42260-300 Professional Svcs (GENE 3 Quantitative fit test		\$105.00
Invoice	42841	2/20/2023	
Cash Payment	E 101-42260-300 Professional Svcs (GENE Processing fee		\$15.00
Invoice	42841	2/20/2023	
Transaction Date	3/2/2023	PRAIRIE SUN BANK 10100	Total \$120.00
Refer	<u>656 WIDSETH SMITH NOLTING & ASS</u>	<u>Ck# 019633 3/13/2023</u>	
Cash Payment	E 603-49500-300 Professional Svcs (GENE BV Demolition Landfill Survey		\$900.00
Invoice	222191	2/23/2023	
Transaction Date	3/2/2023	PRAIRIE SUN BANK 10100	Total \$900.00
Refer	<u>657 JOHN DEERE FINANCIAL</u>	<u>Ck# 019606 3/2/2023</u>	
Cash Payment	E 101-43000-220 Repair/Maint Supply (GE 5 g hytran for payloader		\$187.67
Invoice	3629579	1/25/2023	
Cash Payment	E 101-45000-220 Repair/Maint Supply (GE 5 g hytran for payloader		\$34.12
Invoice	3629579	1/25/2023	
Cash Payment	E 603-49500-220 Repair/Maint Supply (GE 5 g hytran for payloader		\$85.31
Invoice	3629579	1/25/2023	
Cash Payment	E 602-49450-220 Repair/Maint Supply (GE 5 g hytran for payloader		\$17.06
Invoice	3629579	1/25/2023	
Cash Payment	E 601-49400-220 Repair/Maint Supply (GE 5 g hytran for payloader		\$17.06
Invoice	3629579	1/25/2023	
Transaction Date	3/2/2023	PRAIRIE SUN BANK 10100	Total \$341.22
Refer	<u>658 MN DEPT OF REVENUE ST</u>	<u>Ck# 013165E 3/2/2023</u>	
Cash Payment	E 601-49400-441 Sales tax	Comm Water	\$39.00
Invoice			
Cash Payment	E 603-49500-441 Sales tax	Comm Garbage	\$306.00
Invoice			
Cash Payment	E 603-49500-441 Sales tax	Res Garbage	\$388.00
Invoice			
Transaction Date	3/2/2023	PRAIRIE SUN BANK 10100	Total \$733.00
Refer	<u>659 MN DEPT OF REVENUE SW</u>	<u>Ck# 013164E 3/2/2023</u>	
Cash Payment	G 101-21702 State Withholding	Feb 16-28	\$452.09
Invoice			
Transaction Date	3/2/2023	PRAIRIE SUN BANK 10100	Total \$452.09
Refer	<u>660 BLUE CROSS BLUE SHIELD OF MN</u>	<u>Ck# 013166E 3/15/2023</u>	

BROWNS VALLEY, MN

03/08/23 3:16 PM

Page 2

Payments

Current Period: March 2023

Cash Payment	G 101-21710 Other Deductions	Feb employee vision ins		\$12.82
Invoice	230301377910	3/15/2023		
Transaction Date	3/2/2023	PRAIRIE SUN BANK 10100	Total	\$12.82
Refer	661 IRS	<u>Ck# 013167E 3/2/2023</u>		
Cash Payment	G 101-21701 Federal Withholding	Federal		\$601.80
Invoice				
Cash Payment	G 101-21703 FICA Tax Withholding	SS & Medicare		\$2,105.38
Invoice				
Transaction Date	3/2/2023	PRAIRIE SUN BANK 10100	Total	\$2,707.18
Refer	662 PUBLIC EMPLOYEES RETIREMEN	<u>Ck# 013168E 3/2/2023</u>		
Cash Payment	G 101-21704 PERA	Feb 16-28		\$1,098.06
Invoice				
Transaction Date	3/2/2023	PRAIRIE SUN BANK 10100	Total	\$1,098.06
Refer	663 AFLAC	<u>Ck# 013169E 3/2/2023</u>		
Cash Payment	G 101-21708 AFLAC	February		\$521.93
Invoice				
Transaction Date	3/2/2023	PRAIRIE SUN BANK 10100	Total	\$521.93
Refer	664 BROWNS VALLEY HARDWARE HA	<u>Ck# 019614 3/13/2023</u>		
Cash Payment	E 101-43000-220 Repair/Maint Supply (GE	Sweeper repair		\$4.59
Invoice				
Cash Payment	E 601-49400-220 Repair/Maint Supply (GE	Well bushing		\$4.59
Invoice				
Cash Payment	E 101-42260-210 Operating Supplies (GEN	fire dept supplies		\$122.90
Invoice				
Cash Payment	E 101-42260-220 Repair/Maint Supply (GE	fire dept repairs		\$218.69
Invoice				
Cash Payment	E 101-42153-210 Operating Supplies (GEN	ambulance supplies		\$149.99
Invoice				
Cash Payment	E 101-43000-210 Operating Supplies (GEN	shop supplies		\$74.46
Invoice				
Cash Payment	E 101-45000-210 Operating Supplies (GEN	shop supplies		\$37.23
Invoice				
Cash Payment	E 601-49400-210 Operating Supplies (GEN	shop supplies		\$22.33
Invoice				
Cash Payment	E 602-49450-210 Operating Supplies (GEN	shop supplies		\$14.89
Invoice				
Cash Payment	E 101-41000-220 Repair/Maint Supply (GE	community center door repairs		\$189.97
Invoice				
Cash Payment	E 101-43000-210 Operating Supplies (GEN	safety hasp		\$11.49
Invoice				
Transaction Date	3/3/2023	PRAIRIE SUN BANK 10100	Total	\$851.13
Refer	665 HENRY SCHEIN, INC	<u>Ck# 019620 3/13/2023</u>		
Cash Payment	E 101-42153-210 Operating Supplies (GEN	ambulance supplies		\$1,596.46
Invoice	33670547	1/25/2023		
Transaction Date	3/3/2023	PRAIRIE SUN BANK 10100	Total	\$1,596.46
Refer	666 CHS INC.	<u>Ck# 019618 3/13/2023</u>		

BROWNS VALLEY, MN

03/08/23 3:16 PM

Page 3

Payments

Current Period: March 2023

Cash Payment Invoice	E 101-41000-383 Gas Utilities	LP City Hall/Amb/Fire 2/3/23	\$209.72
Cash Payment Invoice	E 101-42153-383 Gas Utilities	LP City Hall/Amb/Fire 2/3/23	\$209.71
Cash Payment Invoice	E 101-42260-383 Gas Utilities	LP City Hall/Amb/Fire 2/3/23	\$209.71
Cash Payment Invoice	E 101-41000-383 Gas Utilities	LP Comm Center	\$487.36
Cash Payment Invoice	E 101-43000-383 Gas Utilities	Shop Heat Ruby Fieldmaster	\$285.17
Cash Payment Invoice	E 101-45000-383 Gas Utilities	Shop Heat Ruby Fieldmaster	\$142.59
Cash Payment Invoice	E 601-49400-383 Gas Utilities	Shop Heat Ruby Fieldmaster	\$85.55
Cash Payment Invoice	E 602-49450-383 Gas Utilities	Shop Heat Ruby Fieldmaster	\$57.03
Cash Payment Invoice	E 101-43000-383 Gas Utilities	LP City Hall/Amb/Fire 2/28/23	\$189.10
Cash Payment Invoice	E 101-42153-383 Gas Utilities	LP City Hall/Amb/Fire 2/28/23	\$189.11
Cash Payment Invoice	E 101-42260-383 Gas Utilities	LP City Hall/Amb/Fire 2/28/23	\$189.11
Transaction Date	3/6/2023	PRAIRIE SUN BANK 10100	Total \$2,254.16
Refer	667 DUFFIELD, DAVID	Ck# 019619 3/13/2023	
Cash Payment Invoice	E 601-49400-333 Freight and Express	transport shipping container	\$250.00
Transaction Date	3/6/2023	PRAIRIE SUN BANK 10100	Total \$250.00
Refer	668 TRI STATE WATER, INC.	Ck# 019630 3/13/2023	
Cash Payment Invoice	E 101-41000-200 Office Supplies (GENER	Cust #1029106	\$29.35
Transaction Date	3/7/2023	PRAIRIE SUN BANK 10100	Total \$29.35
Refer	669 OTTERTAIL POWER COMPANY	Ck# 019626 3/13/2023	
Cash Payment Invoice	E 101-43160-381 Electric Utilities	14-010655 Christmas lights	\$354.64
Transaction Date	3/7/2023	PRAIRIE SUN BANK 10100	Total \$354.64
Refer	670 TRAVERSE ELECTRIC COOP, INC	Ck# 013170E 3/15/2023	
Cash Payment Invoice	E 601-49400-381 Electric Utilities	monthly statement (water)	\$40.86
Cash Payment Invoice	E 602-49450-381 Electric Utilities	monthly statement (wastewater)	\$112.28
Transaction Date	3/7/2023	PRAIRIE SUN BANK 10100	Total \$153.14
Refer	671 VALLEY SOFT WATER, INC.	Ck# 019631 3/13/2023	
Cash Payment Invoice 12908	E 101-42260-210 Operating Supplies (GEN	softener salt 2/1/23	\$27.00
Cash Payment Invoice 12908	E 101-42260-410 Rentals (GENERAL)	softener rental 3/1/23 to 6/1/23	\$60.00
Transaction Date	3/7/2023	PRAIRIE SUN BANK 10100	Total \$87.00

BROWNS VALLEY, MN

03/08/23 3:16 PM

Page 4

Payments

Current Period: March 2023

Refer	<u>672 AMBULANCE CLAIMS PROCESSIN</u>	<u>Ck# 019608 3/13/2023</u>		
Cash Payment	E 101-41000-300 Professional Srvs (GENE February billing			\$110.00
Invoice	17776	2/28/2023		
Transaction Date	3/7/2023	PRAIRIE SUN BANK 10100	Total	\$110.00
Refer	<u>673 VALLEY TELEPHONE</u>	<u>Ck# 019632 3/13/2023</u>		
Cash Payment	E 602-49450-321 Telephone	2871,2872,2243,lift stations		\$110.96
Invoice				
Cash Payment	E 101-41000-321 Telephone	2127, Fax Village Hall		\$38.88
Invoice				
Cash Payment	E 101-41000-321 Telephone	Village Hall		\$309.93
Invoice				
Cash Payment	E 211-45500-321 Telephone	2318, 2125, Library		\$51.40
Invoice				
Cash Payment	E 101-43000-321 Telephone	2846, Maintenance Dept.		\$44.45
Invoice				
Cash Payment	E 101-45000-321 Telephone	2846, Maintenance Dept.		\$22.23
Invoice				
Cash Payment	E 601-49400-321 Telephone	2846, Maintenance Dept.		\$13.33
Invoice				
Cash Payment	E 602-49450-321 Telephone	2846, Maintenance Dept.		\$8.89
Invoice				
Transaction Date	3/7/2023	PRAIRIE SUN BANK 10100	Total	\$600.07
Refer	<u>674 SEROCKI EXCAVATING, INC.</u>	<u>Ck# 019629 3/13/2023</u>		
Cash Payment	E 601-49400-300 Professional Srvs (GENE Replace curbstop riser			\$824.50
Invoice	14643	3/6/2023		
Cash Payment	E 601-49400-300 Professional Srvs (GENE steamed out curbstop for red house			\$244.50
Invoice	14643	3/6/2023		
Transaction Date	3/7/2023	PRAIRIE SUN BANK 10100	Total	\$1,069.00
Refer	<u>675 BOUND TREE MEDICAL</u>	<u>Ck# 019611 3/13/2023</u>		
Cash Payment	E 101-42153-210 Operating Supplies (GEN ambulance supplies			\$262.32
Invoice	84857456	2/13/2023		
Cash Payment	E 101-42153-210 Operating Supplies (GEN ambulance supplies			\$39.87
Invoice	84859122	2/14/2023		
Transaction Date	3/7/2023	PRAIRIE SUN BANK 10100	Total	\$302.19
Refer	<u>676 BROWNS VALLEY CENEX INC.</u>	<u>Ck# 019613 3/13/2023</u>		
Cash Payment	E 101-42153-212 Motor Fuels	amulance gas		\$37.89
Invoice	2007	2/9/2023		
Transaction Date	3/7/2023	PRAIRIE SUN BANK 10100	Total	\$37.89
Refer	<u>677 MN DEPARTMENT OF HEALTH</u>	<u>Ck# 019625 3/13/2023</u>		
Cash Payment	E 601-49400-312 License	operators license		\$23.00
Invoice				
Transaction Date	3/7/2023	PRAIRIE SUN BANK 10100	Total	\$23.00
Refer	<u>678 BARBARA CARL</u>	<u>Ck# 019610 3/13/2023</u>		
Cash Payment	E 101-42153-208 Training and Instruction	EMS Refresher course x 5		\$875.00
Invoice	3042023-BV	3/3/2023		
Transaction Date	3/7/2023	PRAIRIE SUN BANK 10100	Total	\$875.00

BROWNS VALLEY, MN

03/08/23 3:16 PM

Page 5

Payments

Current Period: March 2023

Refer	679 <u>CARQUEST OF ORTONVILLE</u>	<u>Ck# 019616 3/13/2023</u>		
Cash Payment	E 101-43000-210 Operating Supplies (GEN 02 Chevy pickup trailer adaptor			\$7.40
Invoice	8923-185258	2/17/2023		
Cash Payment	E 601-49400-210 Operating Supplies (GEN 02 Chevy pickup trailer adaptor			\$3.70
Invoice	8923-185258	2/17/2023		
Cash Payment	E 602-49450-210 Operating Supplies (GEN 02 Chevy pickup trailer adaptor			\$3.69
Invoice	8923-185258	2/17/2023		
Transaction Date	3/8/2023	PRAIRIE SUN BANK 10100	Total	\$14.79
Refer	680 <u>CENEX FLEET CARD</u>	<u>Ck# 019617 3/13/2023</u>		
Cash Payment	E 101-42153-212 Motor Fuels	#3 Ambulance		\$46.87
Invoice				
Cash Payment	E 101-43000-212 Motor Fuels	#4 Maintenance pickups		\$139.71
Invoice				
Cash Payment	E 601-49400-212 Motor Fuels	#4 Maintenance pickups		\$77.06
Invoice				
Cash Payment	E 602-49450-212 Motor Fuels	#4 Maintenance pickups		\$77.08
Invoice				
Cash Payment	E 101-43000-212 Motor Fuels	#4 Maintenance dump truck		\$240.16
Invoice				
Cash Payment	E 101-43000-212 Motor Fuels	#4 Maintenance plow truck		\$203.62
Invoice				
Transaction Date	3/8/2023	PRAIRIE SUN BANK 10100	Total	\$784.50
Refer	681 <u>MAYNARDS FOOD CENTER</u>	<u>Ck# 019621 3/13/2023</u>		
Cash Payment	E 211-45500-210 Operating Supplies (GEN library supplies			\$3.99
Invoice	3859	2/2/2023		
Transaction Date	3/8/2023	PRAIRIE SUN BANK 10100	Total	\$3.99
Refer	682 <u>BROWNS VALLEY HARDWARE HA</u>	<u>Ck# 019615 3/13/2023</u>		
Cash Payment	E 211-45500-210 Operating Supplies (GEN library supplies			\$6.99
Invoice	12998	2/11/2023		
Transaction Date	3/8/2023	PRAIRIE SUN BANK 10100	Total	\$6.99
Refer	683 <u>MIDWEST TAPE LLC</u>	<u>Ck# 019623 3/13/2023</u>		
Cash Payment	E 211-45500-435 Books and Pamphlets	digital books		\$49.95
Invoice	503440664	3/1/2023		
Cash Payment	E 211-45500-437 Tapes/CD s/Movies	digital movies		\$8.97
Invoice	503440664	3/1/2023		
Transaction Date	3/8/2023	PRAIRIE SUN BANK 10100	Total	\$58.92
Refer	684 <u>BAKER & TAYLOR</u>	<u>Ck# 019609 3/13/2023</u>		
Cash Payment	E 211-45500-435 Books and Pamphlets	books		\$45.33
Invoice	2037355318	2/27/2023		
Cash Payment	E 211-45500-333 Freight and Express	books		\$0.45
Invoice	2037355318	2/27/2023		
Transaction Date	3/8/2023	PRAIRIE SUN BANK 10100	Total	\$45.78
Refer	685 <u>SAFETY-KLEEN</u>	<u>Ck# 019627 3/13/2023</u>		
Cash Payment	E 601-49400-210 Operating Supplies (GEN parts washer solvent			\$76.86
Invoice	91080508	2/24/2023		
Cash Payment	E 602-49450-210 Operating Supplies (GEN parts washer solvent			\$76.87
Invoice	91080508	2/24/2023		

BROWNS VALLEY, MN

03/08/23 3:16 PM

Page 6

Payments

Current Period: March 2023

Cash Payment	E 101-43000-210 Operating Supplies (GEN parts washer solvent			\$76.86
Invoice	91080508	2/24/2023		
Transaction Date	3/8/2023	PRAIRIE SUN BANK	10100	Total \$230.59
Refer	686 MIKE JACOBSON	Ck# 019624	3/13/2023	
Cash Payment	E 101-42400-300 Professional Srvs (GENE March			\$400.00
Invoice				
Transaction Date	3/8/2023	PRAIRIE SUN BANK	10100	Total \$400.00
Refer	687 PEIP	Ck# 013171E	3/8/2023	
Cash Payment	G 101-21706 Health Insurance	April billing		\$3,454.62
Invoice	1268878	3/10/2023		
Transaction Date	3/8/2023	PRAIRIE SUN BANK	10100	Total \$3,454.62
Refer	688 BUSINESS CARD	Ck# 019607	3/8/2023	
Cash Payment	E 211-45500-210 Operating Supplies (GEN library supplies			\$8.67
Invoice				
Cash Payment	E 211-45500-437 Tapes/CD s/Movies	dvd's		\$37.92
Invoice				
Cash Payment	E 101-41000-322 Postage	late fee		\$29.00
Invoice				
Cash Payment	E 211-45500-433 Dues and Subscriptions	MLA Membership		\$30.00
Invoice				
Cash Payment	E 211-45500-435 Books and Pamphlets	books		\$31.41
Invoice				
Cash Payment	E 211-45500-437 Tapes/CD s/Movies	dvd's		\$34.92
Invoice				
Transaction Date	3/8/2023	PRAIRIE SUN BANK	10100	Total \$171.92

Fund Summary

	10100 PRAIRIE SUN BANK
101 GENERAL FUND	\$21,711.03
211 LIBRARY	\$310.00
601 WATER FUND	\$1,722.34
602 SEWER FUND	\$478.75
603 REFUSE (GARBAGE) FUND	\$1,679.31
	<u>\$25,901.43</u>

Pre-Written Checks	\$25,901.43
Checks to be Generated by the Computer	\$0.00
Total	\$25,901.43



PROPOSAL FORM
 Otter Tail Telcom, LLC
 230 W Lincoln Ave
 Fergus Falls, MN
 56537218.998.2000

Proposal Submitted To: City of Browns Valley

Date: 11/22/22

Phone: 320-695-2110

Address: 19 3rd St South PO Box 334

City, State, Zip: Browns Valley, MN 56219

RE: ATTN: Jodi

We hereby submit specifications and estimates for:

- | | |
|---|-------------|
| 1- Ubiquiti UDM Pro SE Security Gateway W/8 POE Ports | \$29.00/mo. |
| 1- Ubiquiti 4TB Internal Hard Drive | \$ 6.95/mo. |
| 1- Ubiquiti G3 Bullet Camera Indoor | \$11.00/mo. |
| 1- Ubiquiti G3 Pro Camera Outdoor | \$22.00/mo. |

Misc. Materials: Wire/Connectors \$150.00

Installation-Training-Programing \$660.00

Form 1000-1 (Rev. 11/2018)

(Faint, illegible text, likely bleed-through from the reverse side of the page)

(Faint, illegible text, likely bleed-through from the reverse side of the page)

(Faint, illegible text, likely bleed-through from the reverse side of the page)

(Faint, illegible text, likely bleed-through from the reverse side of the page)

(Faint, illegible text, likely bleed-through from the reverse side of the page)



Jodi Hook-Hansen

From: Becky Samuelson <becky.samuelson@parkregion.com>
Sent: Wednesday, March 8, 2023 9:07 AM
To: Jodi Hook-Hansen
Cc: Scott Toso
Subject: RE: City of Browns valley -Quotes

Jodi,

I spoke with Dan and Scott and for the wireless this is what we can do:
We would need to add another 8 port switch for \$14.00/month
2-Ap Pro Access Points at \$10.00 each for additional \$20.00/month
So monthly bill would increase \$34.00/month and
2 hours of labor for installation, \$220.00.

We can get this on the schedule for this Friday if you would like to go with it.

Thank you



Becky Samuelson • Customer Service & Sales Representative • Park Region
Office 218.998.2000 • Direct 218.998.1133 • Fax 218.998.2050

2023 Decoration Sale - Sale ends March 31, 2023

Decorations include: C7 LED Crystal Cut Bulbs & all mounting hardware

4' White Line		Bulbs	Sale		5'-6' White Line		Bulbs	Sale
2.5' Star Snowflake	42	\$301		5' Fancy Forked	90	\$429		
3' Single Spiral	54	\$372		6' Cascading	103	\$602		
3' Deluxe SnoBurst	42	\$276		6' Designer Star	54	\$474		
3.5' Fancy Fork	48	\$341		6' Diamond Lace	72	\$490		
4' Designer Star	37	\$365		6' Diamond SF	60	\$420		
4' Diamond SF	48	\$324		6' Reindeer	58	\$478		
4' Single Spiral SF	72	\$456		6' Spiral Lace	84	\$517		
				6' Star SF	84	\$441		
3' - 4' Bright Line		Bulbs	Sale		6' Bright Line		Bulbs	Sale
4' Soldier	50	\$410		5' Holly Leaf (New)	88	\$448		
4' Angel with Horn	55	\$407		5' Gift Box (New)	80	\$448		
4' Single Bell	50	\$360		6' Double Bell	100	\$591		
4' Poinsettia	53	\$388		6' Double Poinsettia	84	\$449		
4' Candle with Halo	40	\$349		6' Angel w/Halo	90	\$480		
4' Candy Cane with Bow	59	\$333		6' Candle with Halo	59	\$393		
4' Candy Cane Swirl	42	\$267		6' Candy Cane with Bow	91	\$430		
4' Ball Ornament	76	\$399		6' Candy Cane Swirl	66	\$357		
4' Wreath with Bow	61	\$335		6' Snowman	70	\$497		
4' ZigZag Tree	44	\$269		6' Soldier	82	\$490		
4' Double Star	68	\$461		6' Stocking	52	\$396		
				6' Christmas Tree	60	\$360		
4' DazzLED		Bulbs	Sale		6' DazzLED		Bulbs	Sale
4' Single Bell - Garland	40	\$419		6' Zig Zag Tree	58	\$418		
4' Poinsettia - Garland	43	\$439		6' Waving Santa	139	\$771		
4' Candle with Halo - Garland	40	\$394		6' Single Bell	82	\$430		
4' Candy Cane Bow *CW bulbs	49	\$359		6' French Horn	50	\$795		
4' Candy Cane Swirl - Garland	33	\$336		6' Triple Star	57	\$519		
4' Diamond SF - Garland	48	\$426						
4' Ornament Ball - Garland	60	\$445						
4' Wreath w/Bow - Garland	48	\$340						
4' Zig Zag Tree - Garland	31	\$360						
4' Single Spiral - Garland	68	\$546						
				6' Double Poinsettia - Garland	72	\$516		
RED HOT DEALS		Bulbs	Sale	Qty	6' Angel- Garland	68	\$666	
3' Fancy Fork - SM- Limited Qty	48	\$289	134	6' Candle with Halo - Garland	46	\$442		
3' Deluxe Snoburst - PM - Limited Qty	36	\$274	185	6' Candy Cane Bow *CW bulbs	66	\$450		
36" Bow Wreath PM - Limited Qty	30	\$299	31	*CW bulbs	66	\$450		
36" Triple Candle Wreath - Limited Qty	30	\$399	4	6' Diamond SF - Garland	72	\$575		
40" Bow Wreath SM- Limited Qty	40	\$389	65	6' Reindeer Garland gold antlers/r	45	\$560		
40" Candle Wreath SM - Limited Qty	40	\$479	50	6' Snowman - Garland	57	\$699		
50" Candle Wreath PM - Limited Qty	42	\$550	36	6' Soldier - Garland	64	\$560		
50" Bow Streetline	54	\$878	3	6' Spiral Lace SF - Garland	72	\$567		
50" Bow Wreath Streetline	102	\$1,389	10	6' Stocking - Garland	56	\$467		
3' Loop Tree - BL	45	\$329	14	6' Christmas Tree - Garland	51	\$531		
4' Gift Box - Garland	53	\$369	11	6' Zig Zag Tree - Garland	49	\$453		
4' Designer Star - Garland	27	\$316	12	6' Waving Santa - Garland	125	\$912		
6' Gift Box - Garland	87	\$499	18	6' Single Bell - Garland	65	\$475		
6' Designer Star - Garland	42	\$466	8	6' French Horn - Garland	44	\$619		
6' Holly Leaf - Garland	62	\$469	3					

*No modifications - PMs have silver hardware

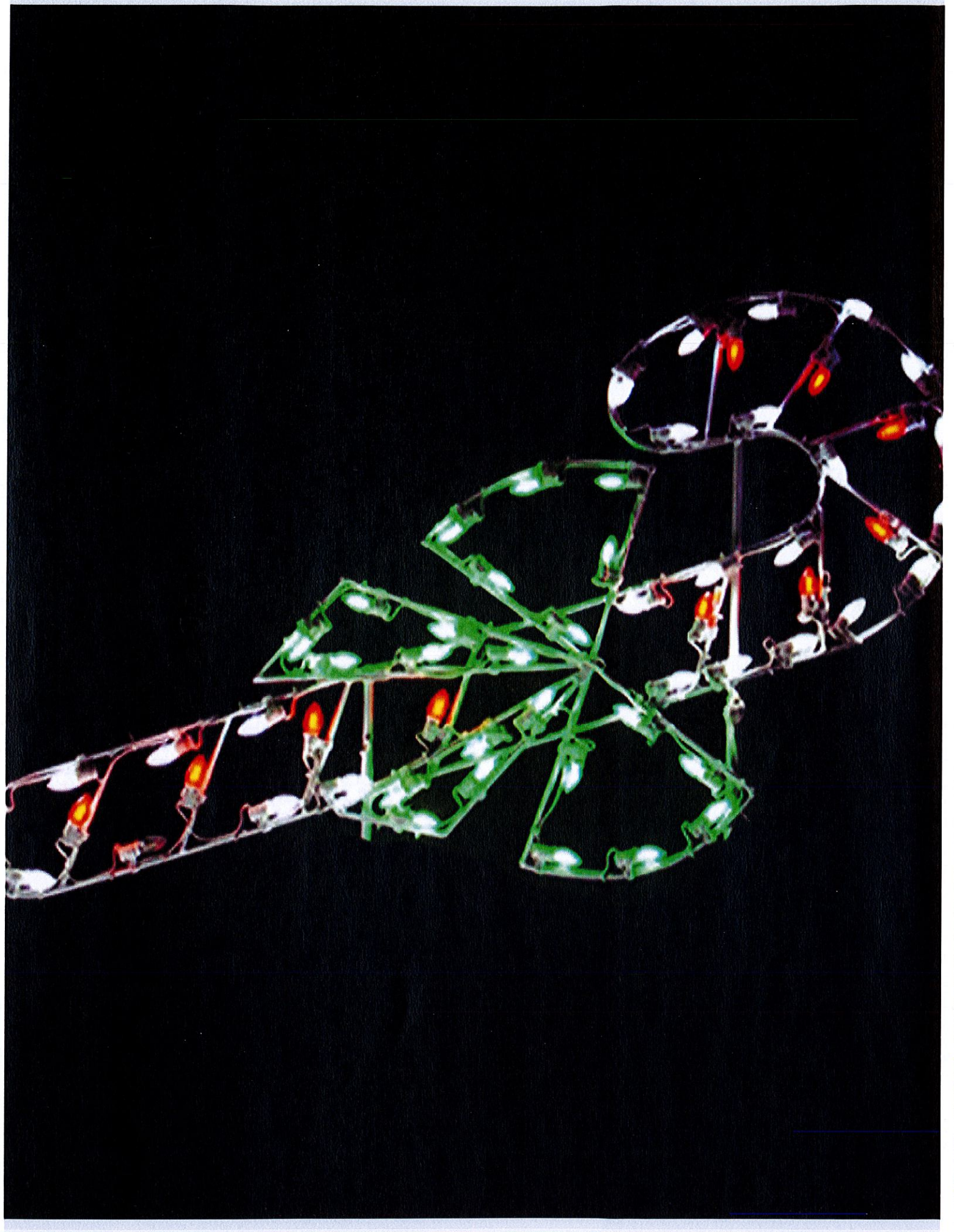

BROWNS VALLEY, IN TIER Report

3/8/2023 10:52

Page 1

Groups 01
Services 1

Range: Grp 01, Per 2, Year 2023

Account Type:

***** Rate#

RES, MTR	WTR	Residential		*** Account	R	COUNT
		FROM	TO			
1	1000	19028	0.0035	\$66.60	0.0035	53
1001	2000	63854	0.0035	\$223.49	0.0035	44
2001	3000	105142	0.0035	\$368.00	0.0035	42
3001	4000	115599	0.0035	\$404.60	0.004	33
4001	5000	90579	0.0035	\$317.03	0.004	20
5001	6000	64551	0.0035	\$225.93	0.004	12
6001	7000	89804	0.0035	\$314.31	0.0045	14
7001	8000	51804	0.0035	\$181.31	0.0045	7
8001	9000	17081	0.0035	\$59.78	0.0045	2
9001	10000	47911	0.0035	\$167.69	0.005	5
10001	11000	22620	0.0035	\$79.17	0.005	1
11001	12000	12224	0.0035	\$42.78	0.005	2
12001	13000	392785	0.0035	\$1,374.75	0.0055	11
13001	14000		0.0035	\$0.00	0.0055	
14001	15000		0.0035	\$0.00	0.0055	
15001	999999999		0.0035	\$0.00	0.0035	
RES, MTR		1,092,982		\$3,825		246

Base Rate 246 Users X \$20 Base Rate = \$4920.00 246 Users

*Still receiving more
Information from Kurt
and other cities*

Jodi Hook-Hansen

From: Tony Serocki <tserocki@prtcl.com>
Sent: Friday, March 10, 2023 9:11 AM
To: 'Jodi Hook-Hansen'
Subject: FW: Para Glide
Attachments: 00131899.pdf; 00116567.pdf

From: Fargo Service <fargoservice@ntecorp.com>
Sent: Thursday, March 9, 2023 3:32 PM
To: tserocki@prtcl.com
Subject: Para Glide

Here are the parts you will need for the paraglide.

00116567	WING POST ASSY,RHFR,PARA,34" 14.5"L TUBE,1.375 HINGE	
PIN	\$7,600.00	
00131899	SIDE PL,WING,PARA-GLIDE,.750 18" X 28"	\$490.00

Both are in stock at Monroe. Price doesn't include freight.

Thanks,

Evan Laudal

Northern Truck Equipment Corp.
3475 SW 38th Street
Fargo ND 58104
Ph. 701-281-1718

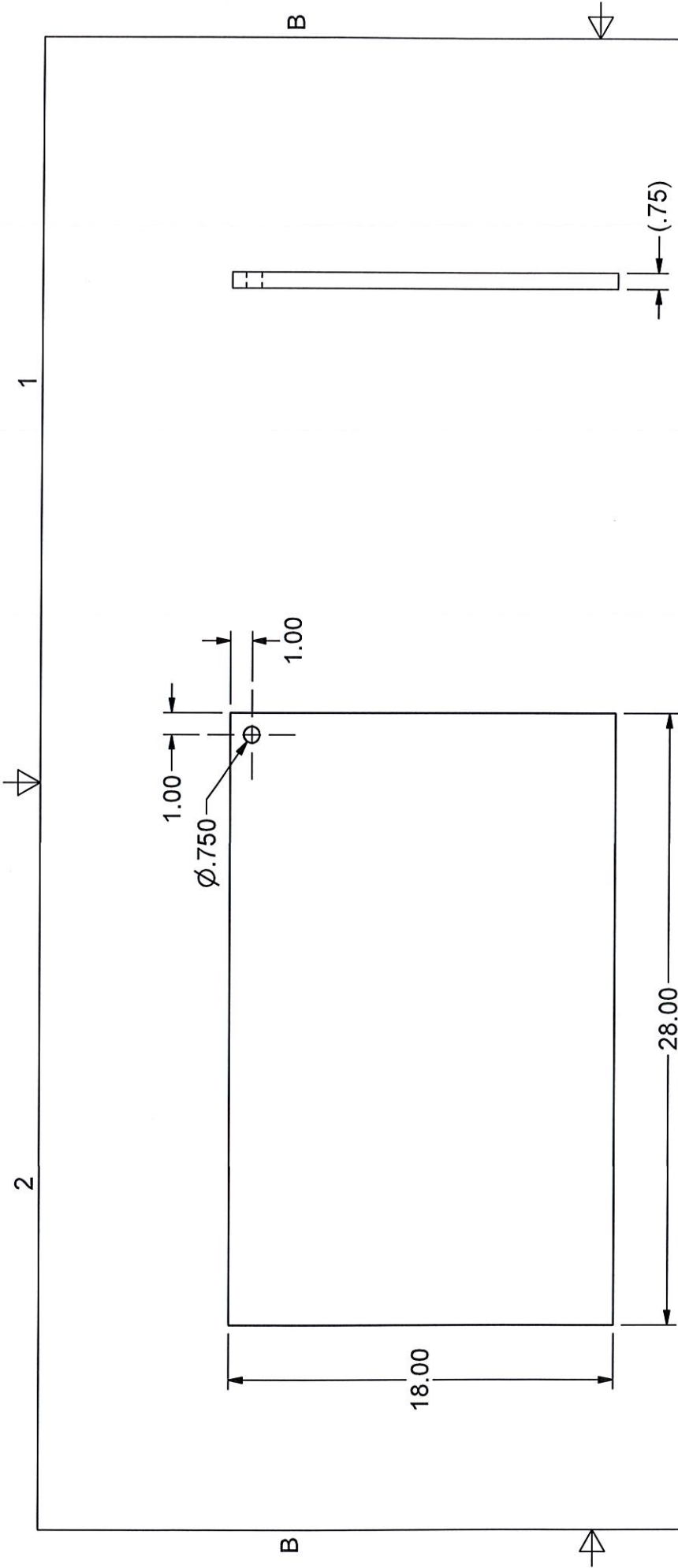

- REMOVE ALL BURRS AND SHARP EDGES.
- DIMENSIONS SHOWN IN () ARE REFERENCE ONLY.

MATERIAL: PLATE,MS,.750,HR A36



1051 West 7th Street
Monroe, WI 53566-9100
608-328-8127

TITLE
SIDE PLATE, WING, PARA-GLIDE
.750

TOLERANCES UNLESS OTHERWISE INDICATED	AUTHORIZATION	DATE	REV. NO:	ADDED CORNER RADIUS	MCF	JTC	8/27/2014
.XX \pm .06 .XXX \pm .031	DRAWN BY: BTK CHECKED BY: TLC APPROVED BY:	2/21/2011 2/21/2011	1	RELEASED, ECR# 10035	BTK	X	2/21/2011
	SQ. FT.: 3.497	LBS: 107		REVISION	INITIALS	DATE	
	THIRD ANGLE PROJECTION	MFG CODE					
		D					
	This drawing is the property of Monroe Truck Equipment and is loaned to you for use on the specific part to which it applies. It is not to be used in whole or part to assist in the making of drawings, prints, apparatus, or parts thereof without written permission.						
	SCALE	SIZE	PART NUMBER	SHEET			
	.15"=1"	A	00131899	1 of 1			

